



hermanos
garcía
REMOLQUES

REMOLQUES MULTIUSOS / REMORQUES MULTI-USAGES



TRANSPORTE DE PIENSOS / transport de fourrage



MZG 162

MZG 162



MODELOS / MODÉLES:

MZG 132* MZG 162 MZG 222

M3

13

16

22

COMPARTIMENTOS / Compartiments

2

2

2

*Posibilidad de 1 eje / Possibilit  d` un essieu

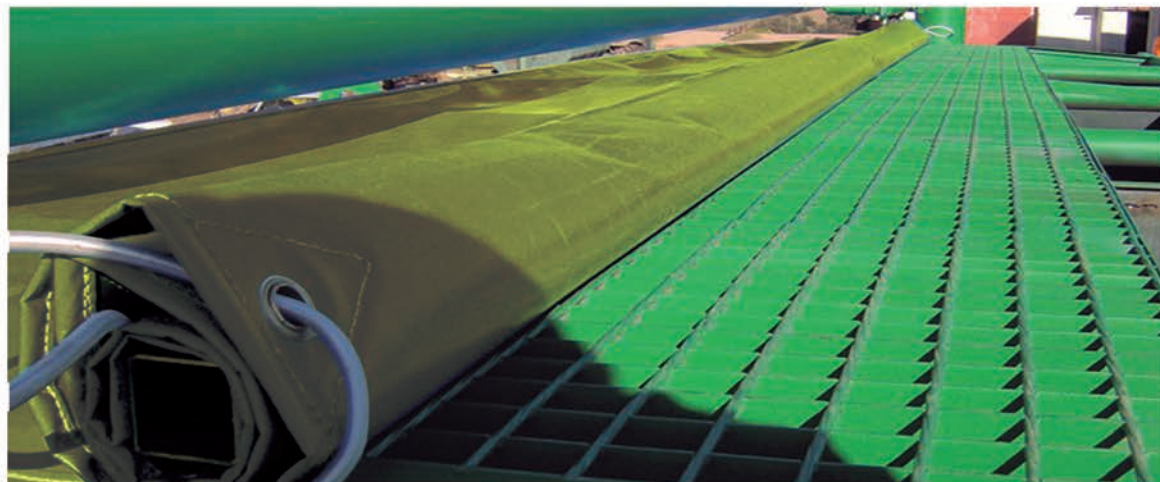

TRANSPORTE DE GANADO / CATTLE TRANSPORTATION

MODELOS / MODELÈS:

Nº DE VACAS / Nº DE VACHES:

SUSPENSIÓN HIDRÁULICA / SUSPENSION



PISO CUBIERTO DE RESINA /
PLANCHER COUVERT DE RÉSINE



SEPARACIÓN INTERIOR /
SÉPARATION INTÉRIEURE

	PG-52	PG-64	PG-74	PG-85
	8/9	12/13	14/15	17/18
HYDRAULIQUE:	2 CIL	3 CIL	4 CIL	6 CIL

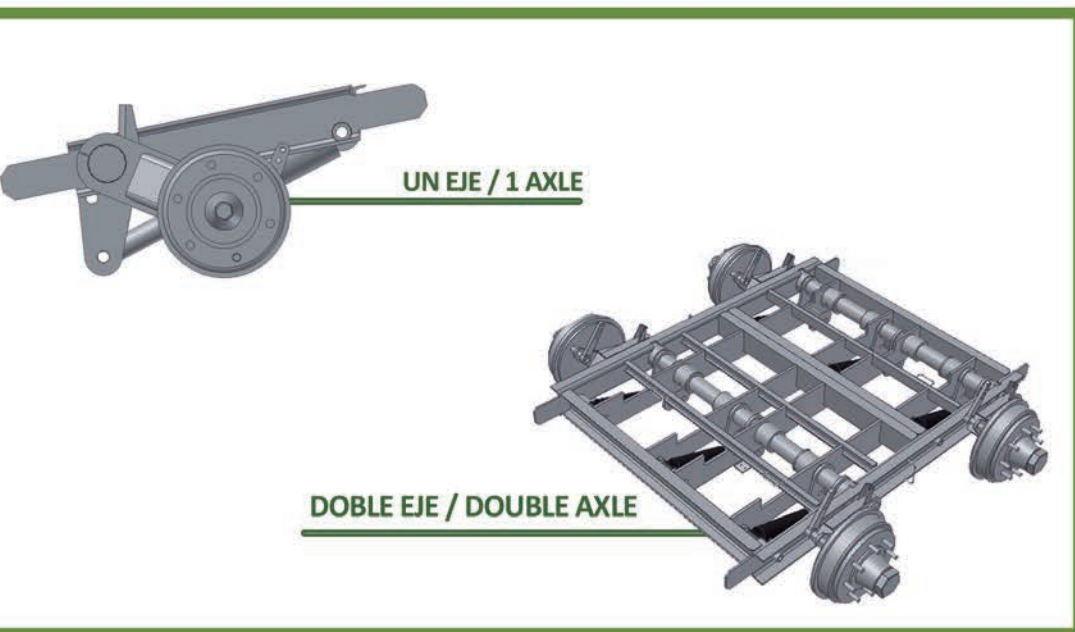

SUSPENSIÓN DE EJES / BOLA DE NITRÓGENO
SUSPENSION SUR ESSIEUX / SYSTÈME DE GAZ AZOTE



SEPARACIÓN INTERIOR CORREDERA /
SÉPARATION INTÉRIÈRE COULISSANTE



PUERTA TRASERA /
PORTE ARRIÈRE

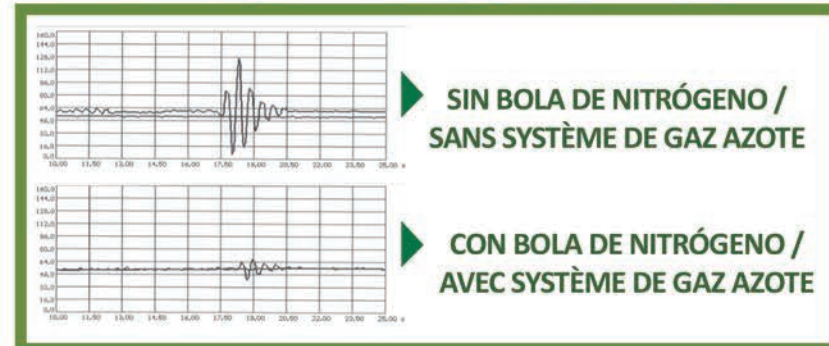

TRANSPORTE DE MÁQUINAS / TRANSPORT DE MACHINES



MODELOS / MODÈLES:

PM-

EJES / ESSIEUX:

DIMENSIONES / DIMENSIONS: 460 - 240

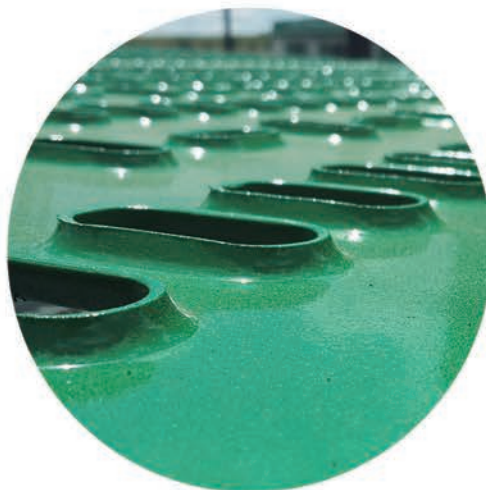

5
1

PM-7
1
710 - 240

PT-18F
2
600 - 245

PT-72F
2
710 - 245

DETALLE SUELO P M /
DÉTAIL PLANCHER P M

DETALLE SUELO P T
DÉTAIL PLANCHER P T

TRANSPORTE DE , PAJA, FORRAJE, CAJONES Y SACAS / TRANSPORT DE PAILLE, FOURRAGE



DE
RÉSER



ALMACÉN, CAJAS Y SACOS

ALMACÉN Y CAJÓN/
BOÎTE À Outils



APOYO HIDRÁULICO
CON BOMBA MANUAL/
BÉQUILLE HYDRAULIQUE AVEC
POMPE MANUELLE



GIRATORIO MODULAR/
SYSTÈME MODULAIRE
TOURNANT



ALARGADERA TRASERA/
RALLONGE ARRIÈRE



FRENO HIDRÁULICO/
FREIN HYDRAULIQUE



FRENO NEÚMATICO/
FREIN D'AIR

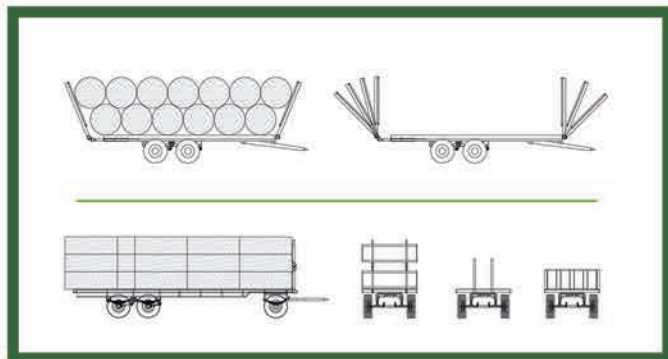

PLANOS DE PARRILLA/
PLANS DE GRILLES



PARTE INFERIOR/
PARTIE INFÉRIÈRE



BALLESTA MULTIHOJA Y ABARCONES REFORZADOS/
SUSPENSION À PLUSIEURS LAMES ET VIS RENFORCÉS





LÍDERES EN CALIDAD LEADERS EN QUALITÉ



DISTRIBUIDOR / DISTRIBUTEUR:



Ctra. Cogeces del Monte, km 0,5 | 47300 Peñafiel - Valladolid (ESPAÑA)
Telf: +34 988 880 011 - Fax: +34 988 881 465
r@remolqueshnosgarcia.com | www.remolqueshnosgarcia.com